

Alignment ensured
by two robust
anti-torsion bars

Robust structure
of scissors, offering
great lateral stability

Hot galvanized base
as standard, painted
scissors, runways
and ramps

Start lever from zero
position to maximum height

TITAN

XC 1350



Reversible low-profile electrohydraulic scissors
lift for cars, SUVs and vans



HYDRAULIC SYSTEM

Redundant hydraulic system with two cylinders per runway, without the need for compressed air and mechanical safety devices.



CONTROL UNIT

Low voltage control unit with "dead-man" control system.



RUNWAYS WITH FLAPS

Runways with hung flaps, which also serve as ramps to get the vehicle on. Their "almond-shaped" structure ensures good manoeuvrability even in wet conditions.



STANDARD ACCESSORIES



RUBBER BLOCKS
Kit of 4 pcs H=40 mm

RECOMMENDED ACCESSORIES



8-41100228 KIT ON CARRIAGE
Consisting of wheels and manual lever



8-42300027 RUBBER BLOCKS
Kit of 4 pcs H=80 mm

See separate catalogue for further accessories.

DIMENSIONS

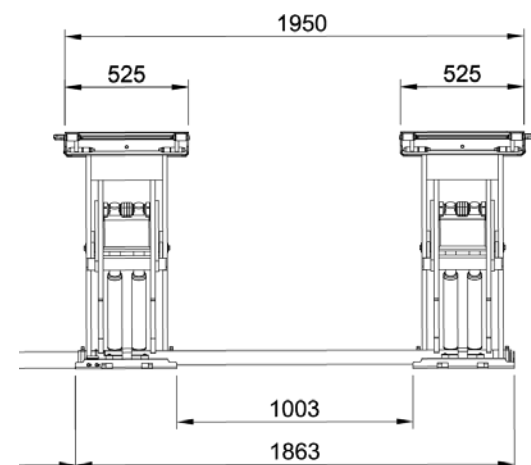
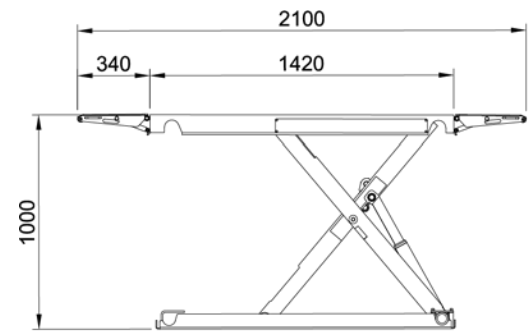

TECHNICAL DATA

Lift capacity	3500 kg
Maximum lifting height	895 mm
Minimum lifting height	105 mm
Working height	1000 mm + tamponi gomma
Lifting/lowering time	16 s
Hydraulic unit	2.2 kW
Voltage	230/400V - 3Ph - 50/60Hz

The manufacturer reserves the right to modify the features of its products at any time.